

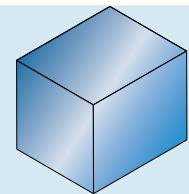

Product Description

The IM-65NE-LM (air cooled) is one of our unique special ice type ice makers tailored for the mixologists and cocktail bars that like to differentiate themselves and add to the full cocktail experience with the uniqueness of ice shapes without eliminating the purpose of properly cooling the drink with minimal dilution. Still part of our IM ice making system this machine is a self-contained under counter models which are suited to place under bars and servicing countertops.

- Can produce up to 40kg of ice per 24 hours respectively (AT.10°C.WT.10°C).
- Unique ice making system that has an automatic rinse cycle. After every new batch of ice, the water reservoir drains and refills with fresh water. System comes with a magnetic water pump that has no direct coupling, which prevents any leakage.
- Closed water circuit offers the ultimate contamination protection, by reducing the number of points at which impurities can enter the ice making process.
- Electronically controlled to ensure an optimised ice making process under varying circumstances without the need for physical adjustments. Quality of ice is always consistent.
- Easily cleanable air filter allows end-users to carry out routine cleaning schedules. Extends product life expectancy and reduces the frequency and costs of maintenance call-outs.
- Stainless steel



Ice Type: Big Cube XXL
Size: 48 x 48 x 58mm / 110g

Production

Model	Ice Production per 24h (Approx.)	Temperature	Ice Production per Cycle (Approx.)	Water Consumption per 24h (Approx.)	Storage Capacity (Approx.)
IM-65NE-LM	40kg 33kg 25kg	AT.10°C, WT.10°C AT.21°C, WT.15°C AT.32°C, WT.21°C	1.44kg / 12pcs	0.87m ³ 0.08m ³ 0.06m ³	26kg

Specifications

Specification	IM-65NE-LM	Operation Requirements
Dimensions W x D x H (mm)	633 x 506 x 860 (Legs add 90-125mm)	Ambient Temperature: 1 - 40°C
AC Supply Voltage	1 Phase 220 - 240V, 50 / 60Hz	Water Supply Temperature: 5 - 35°C
Electric Consumption (AT.21°C, WT.10°C)	390W	Water Supply Pressure: 0.07 - 0.8MPa (0.7 - 8 bar)
Insulation	Polyurethane Foam	Voltage Range: Rated Voltage ± 6%
Insulation Foam Blowing Agent	Water Blown	
Heat Rejection	800W	
Refrigerant Charge	R134a	Accessories
		Scoop, Leg, Installation Kit

For more information visit our website
www.hoshizaki-europe.com

Hoshizaki Europe B.V. retains the right to change products and their specifications without prior notice.





Ice Maker: IM-65NE-LM

Big Cube (XXL)

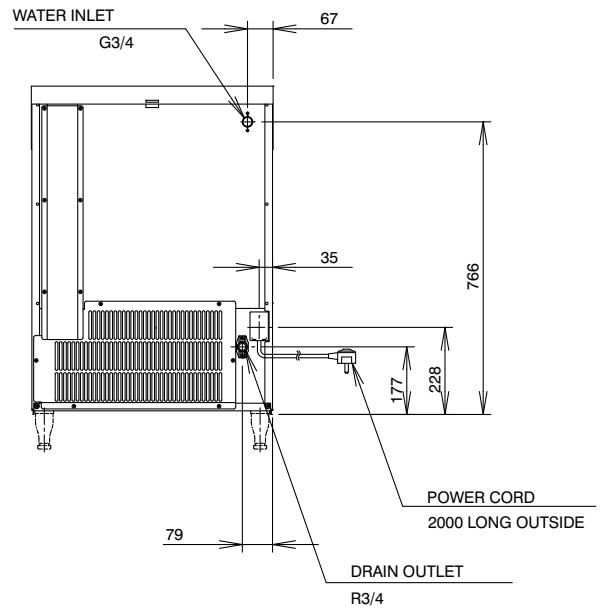
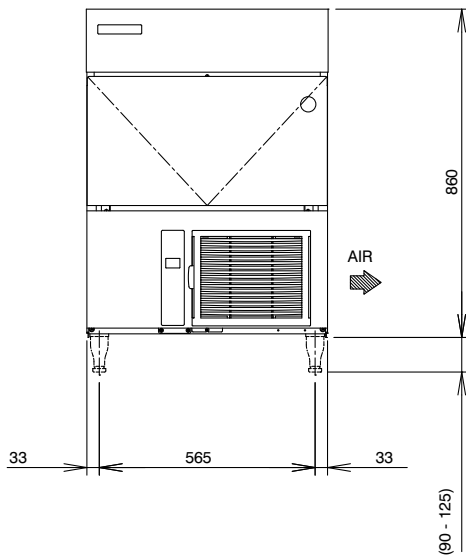
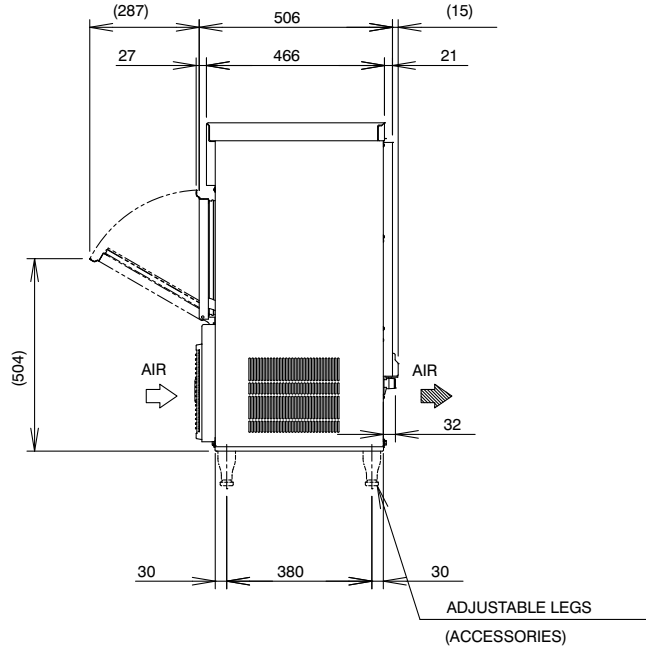
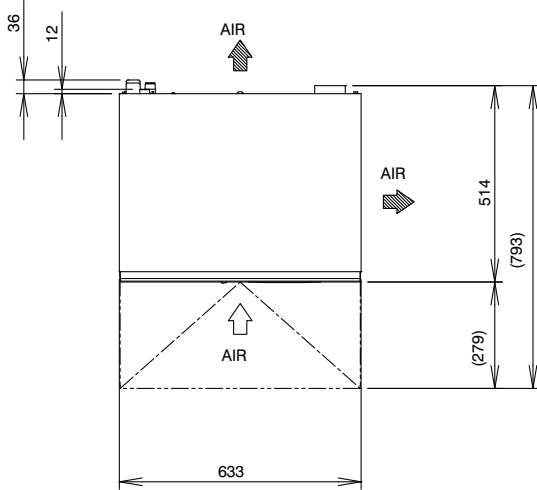

Full CAD specification drawings available on website